

## STRENGTHENING HALAL VALUE CHAIN AS A GUARANTEE OF HALAL PRODUCT AT SLAUGHTERHOUSES: CASE OF A CHICKEN SLAUGHTERHOUSE IN SEMBAYAT AREA

Fatihatus Sahliyah<sup>1\*</sup>, Niswatun Hasanah<sup>2</sup>, Syamsir Alamsyah Harahap<sup>3</sup>, Clairina Cathliniyah Zerlindah<sup>4</sup>

<sup>1,2,3,4</sup> Universitas Qomaruddin Gresik

e-mail: [sahliyah@uqgresik.ac.id](mailto:sahliyah@uqgresik.ac.id)<sup>1</sup>, [hasanah@uqgresik.ac.id](mailto:hasanah@uqgresik.ac.id)<sup>2</sup>,  
[harahap@uqgresik.ac.id](mailto:harahap@uqgresik.ac.id)<sup>3</sup>, [zerlindah@uqgresik.ac.id](mailto:zerlindah@uqgresik.ac.id)<sup>4</sup>

*Submitted:; Accepted:; Published:*

### Abstract

*This research aims to analyze the halal value chain of slaughter and processing in broiler chicken businesses at AFJ JAYA Sembayat in Islamic economic perspective as well as consumers' views of the halal value chain in these businesses. The research method used in this research is field research using a descriptive qualitative approach. Primary data obtained through in-depth interviews with slaughterhouse managers and consumers. The results of the research show that the halal value chain practices for the chicken slaughter process at AFJ JAYA Sembayat are in accordance with the provisions of MUI Fatwa Number 12 of 2009 concerning Halal Slaughter Certification Standards. However, chicken processing practices are not in accordance with the provisions of MUI Fatwa Number 12 of 2009 because they do not separate dirty and clean spaces. AFJ JAYA Sembayat does not yet have halal certification due to a lack of understanding by business owners regarding the importance of halal certification to the Chicken Slaughterhouse industry. However, consumers still choose to continue purchasing because they feel confident that the chicken meat produced is halal and of high quality. All of this is purely caused by a lack of halal literacy so that ongoing counseling and assistance is necessary.*

**Keywords:** *Halal Value Chain, Chicken Slaughter House, Consumer Protection*

### A. INTRODUCTION

As a country with a majority Muslim population, Indonesia has taken a strategy to strengthen the halal value chain in order to achieve the vision of becoming a popular center for Islamic economics in

the world<sup>1</sup>. Halal value chain is defined as a structured effort of the company starting from input to output that can be said to be halal. When making halal products, the supply of raw materials, processing technology used, product packaging, and the final product received by consumers must be considered.<sup>2</sup> This means that in a

---

<sup>1</sup> OPOP Jabar, "Halal Value Chain Jadikan Indonesia Sebagai Pusat Ekonomi Dan Keuangan," n.d., <https://opop.jabarprov.go.id/halal-value-chain-jadikan-indonesia-sebagai-pusat-%0Aekonomi-dan-keuangan->

syariah/,%0A.

<sup>2</sup> Pratiwi Subianto, "Rantai Nilai Dan Perspektif Kesadaran Masyarakat Muslim Akan Makanan Halal," *Conference on Islamic Management Accounting and*

process there is a value chain that must be considered in terms of sharia, health and safety so that it is suitable for consumption and beneficial for consumers.

In Islamic, consuming food must meet the standards of *halalan thayyiban*, avoiding impurities (*najis*), allowed, and safe for health. Humans are forbidden to eat livestock meat unless it is slaughtered according to Islamic rules. However, Islamic law has excluded two animals from the category of carrion, namely locusts and fish with all kinds of animals that live in water.<sup>3</sup> In connection with this, when slaughtering animals must be really considered so that it is valid according to Islamic rules. Thus, it must be clearly known regarding the implementation of animal slaughter, starting from the intention, mention (*tasmiyah*), equipment for slaughtering, procedures, and everything related to slaughtering including its legal provisions. As Allah SWT says in Surah Al-Maidah:3 which means:

*Forbidden to you (are) carrion, blood, pork, and (the meat of) animals slaughtered not in the name of Allah, the strangled, the beaten, the fallen, the gored, and the killed by wild beasts, except that which you slaughter (in time). (Also forbidden) that which is slaughtered for idols, and (likewise) casting lots with the azlam (arrow), (for) it is an ungodly deed. On this day the disbelievers have despaired of overcoming your religion. Therefore, fear them not, but fear Me. On this day I have perfected your religion for you, I have made My favor sufficient for you, and I have approved Islam as your religion. So, whoever is compelled by hunger, not wishing to sin, surely Allah is Forgiving, Merciful. (QS Al. Maidah: 3)*

Rules related to Halal Product Guarantee in Indonesia are regulated by the Ministry of Religion through Law Number

33 of 2014. In this law, food and beverage producers in Indonesia are required to register their products. The government through the MUI Food, Drug and Cosmetics Assessment Institute (LPPOM) has the responsibility of examining and certifying halal food and beverages. This means that LPPOM MUI (Lembaga Pengkajian Pangan Obat- obatan dan kosmetika Majelis Ulama Indonesia) also needs to pay attention and supervise several slaughterhouses related to how livestock are slaughtered. This should be a concern of the halal product guarantee organizing agency to move door to door or pick up the ball. Because based on the initial observations of researchers, it was found that there were several slaughterhouses that did not have halal certification but the place of business already had an NIB (Business Identification Number). There are even some owners of this slaughterhouse business who state that the name of the place of business does not need halal certification, only the food needs to be halal certified. This means that there are still many people who own animal slaughtering businesses who do not understand the importance of halal labeling through halal certification at slaughterhouses. Where, in determining whether the place of business deserves halal certification through the halal value chain process. Where in the process of slaughtering animals must not ignore the slaughter and processing processes that are contrary to Islamic principles.

One of the livestock processing industry sectors that is the concentration of researchers is the AFJ JAYA Chicken Slaughterhouse (RPA). This RPA is located in Sembayat, Manyar District, Gresik. This industrial house plays an important role in meeting the needs of chicken meat for the Sembayat Village community and its surroundings. Customers include chicken traders, food stalls and many individuals. Based on the initial observations of researchers, customers do not make purchases directly to the location so they do

not know the slaughter and processing process at AFJ JAYA Sembayat Chicken Slaughterhouse. If it is associated with halal value chain activities in operations activities, then customers do not know the slaughter practices carried out at the Chicken Slaughterhouse (RPA) are in accordance with Islamic law or not. This is where the importance of RPA actors guaranteeing halal value chain activities which are then legalized in the form of halal certification for business actors, especially to guarantee the protection of Muslim consumers of halal food.

Previous research explains that slaughterhouses that already have halal certification will facilitate certification for restaurants and processed meat businesses, so that halal certification at slaughterhouses will be sustainable to achieve a halal value chain for restaurants and the processed meat food industry.<sup>4</sup> Meanwhile,<sup>5</sup> focuses on the traceability system in slaughterhouses using the SCOR model approach to determine activities in slaughterhouses and then provides recommendations for the Halal Traceability System (HTS) model to maintain the integration of halal quality of chicken meat.

The research gap that will be examined by researchers is true that there have been many studies examining the halal value chain in slaughtering in chicken slaughterhouses, but this study focuses more on the slaughtering process and consumer protection of halalness in slaughtering chickens in chicken slaughterhouses in the Sembayat Manyar Gresik area. This means that there are many chicken supplies that are traded around the area. So it is important for the

public to know the process of slaughtering chickens in these two areas and the guarantee of halal products.

The formulation of the problem in this study is:

1. How is the *halal value chain* in Chicken Slaughterhouse in Sembayat Manyar Gresik area?
2. How do consumers think about the *halal value chain* at the Chicken Slaughterhouse in the Sembayat Manyar Gresik area?

### **Halal Value Chain**

*Value chain* is a process description to view a business as a chain of activities that transforms *inputs* into *outputs that are valuable to consumers*. *Value chain* analysis seeks to understand how a business creates value for customers.<sup>6</sup> Porter proposed a value chain model as a tool to identify ways to generate added value for consumers to realize profits (*margins*). Value activities are divided into five *primary* activities and four *support activities*. The primary activities are described sequentially, namely bringing raw materials into the business (*inbound logistics*), then converting them into finished goods (*operations*), shipping the finished goods (*outbound logistics*), selling the goods (*marketing and sales*) and providing after-sales service (*service*). Meanwhile, *support activities* are activities carried out by the company so that the sustainability of the main activities can run properly, namely *firm infrastructure*, *human resource* management, *technology* development, and *procurement*.<sup>7</sup>

<sup>4</sup> Subianto, "Rantai Nilai Dan Perspektif Kesadaran Masyarakat Muslim Akan Makanan Halal."

<sup>5</sup> Muhammad Lutfi Siregar and Afuan Zahradika, "Halal Traceability System (Hts) Untuk Integrasi Halal Meat Supply Chain (Hmsc) Terhadap Proses Industri Daging Ayam Pada Rumah Potong Hewan," *Agroindustrial Technology Journal* 7, no. 1 (2023): 74–87, <https://doi.org/10.21111/atj.v7i1.9418>.

<sup>6</sup> Oktavima Wisdaningrum, "Analisis Rantai Nilai (

Value Chain ) Dalam Lingkungan Internal Perusahaan," *Jurnal Analisa* 1, no. 1 (2013): 40–48.

<sup>7</sup> Amelia Setiawan and Ria Satyarini, "LAPORAN Identifikasi Dan Analisis Value Chain Pada Usaha Kecil Yang Dikelola Mahasiswa Disusun Oleh : Amelia Setiawan , SE ., MAK ., AK ., CISA Ria Satyarini , SE ., MSi Lembaga Penelitian Dan Pengabdian Kepada Masyarakat Universitas Katolik Parahyangan," 2015, 1–22.

The value chain activities can be described as follows:

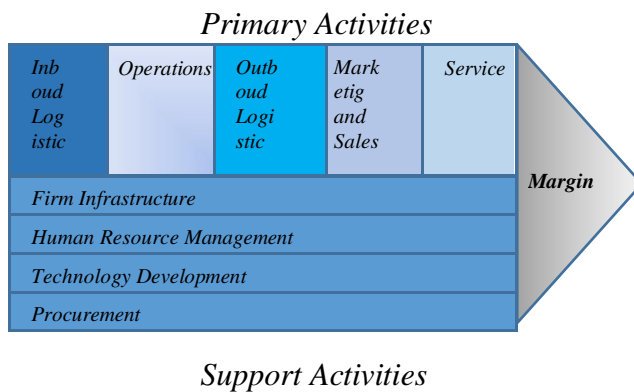
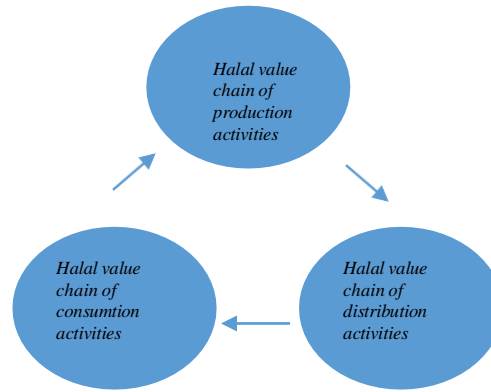

**Figure 1.** Porter's Value Chain

Halal value chain is an integrated effort of the industry from input, production, distribution, marketing and consumption. In producing halal products, raw material input must be considered as well as the processing technology used. In terms of packaging, it must also reflect cleanliness and maintain halalness until the final product is received by Muslim consumers<sup>8</sup>.

Based on the definition of halal value chain above, it can be concluded that to produce a product or service that is truly halal, it is necessary to pay attention to the value chain, starting from the raw materials, the technology used to the distribution.

The value chain is adapted to the halal quality assurance aspect so that it becomes a *halal value chain* with the following activities<sup>9</sup>:



**Figure 2.** Halal Value Chain in Economic Activities

*Halal value chain* activities include halal value chain of *production*, halal value chain of *distribution*, and *halal value chain of consumption*.

One of the elements in charge of carrying out the implementation of halal product guarantees in accordance with the provisions of laws and regulations is the Halal Product Guarantee Agency (BPJPH). BPJPH under the Ministry of Religion is responsible for issuing halal certification which was previously the authority of LPPOM MUI. This is in accordance with Law Number 33 of 2014 concerning Halal Product Guarantee. In the law, the duties and responsibilities of BPJPH are:

- a) Halal Registration
- b) Halal Certification
- c) Halal Verification
- d) Guidance and supervision of halal products
- e) Implementing halal standards of a product

### Previous Research

Research on the *halal value chain* in slaughterhouses has been widely discussed as scientific work. Among them are research related to the design and implementation of a halal assurance system in slaughterhouses.<sup>10</sup>

<sup>8</sup> Subianto, "Rantai Nilai Dan Perspektif Kesadaran Masyarakat Muslim Akan Makanan Halal."

<sup>9</sup> Abdul Siaidir Amir and Waspodo Tjipto Subroto, "The Creating of Halal Value Chains: A Theoretical Approach," *IOSR Journal of Economics and Finance*

10, no. 1 (2019): 14–22, <https://doi.org/10.9790/5933-1001011422>.

<sup>10</sup> Fitri Apriani, "Penerapan Sistem Jaminan Halal Pada Rumah Potong Hewan (Rph) Ruminansia Kota Singkawang," *Cross-Border* 5, no. 2 (2022): 1717–23.

<sup>11, 12</sup> where the research findings reveal that halal certification in slaughterhouses will be sustainable to achieve the halal value chain of restaurants and the processed meat food industry.

Some studies use the Supply Chain Operation Reference (SCOR) model approach.<sup>13 14</sup> to determine and identify all activities in the slaughterhouse.

This research is different from the previous studies that researchers have mentioned above. The difference in this study lies in the object and focus of research, namely the object of research in two large areas in Gresik district, namely Sembayat Manyar. While the focus of the research is the slaughter process at RPA using *Porter's Value Chain* theory and policies made by the local BPJPH regarding RPA.

## B. RESEARCH METHODS

The research was conducted at the RPA in the Sembayat Manyar Gresik area. The location of the RPA is a chicken slaughterhouse located in Sembayat, Mulyorejo Ngampel, Manyar District, Gresik. The location was chosen as the research location on the grounds that in that place the researchers found several research subjects that fit the characteristics or focus of this study. The target research time is 4 months.

The type of research used in this research is descriptive qualitative research with a field research approach because the purpose of this research is to obtain a description, a systematic, factual and accurate description of the phenomenon being investigated. Phenomenon

The subjects in this research are the owner, employees, consumers of Sembayat Chicken Slaughterhouse, one of the community leaders of Sembayat Manyar Gresik Village and the local BPJPH. Primary data obtained comes from the results of in-depth interviews (M) with the sources, namely the subjects in this study. In addition to interviews, data is obtained from observation by collecting data directly to the existing research site through direct observation in the field related to the halal value chain in the slaughter chicken business at the Sembayat Manyar Chicken Slaughterhouse. Documentation is also carried out in research, data can be in the form of field notes, or pictures when researchers are interviewing informants, namely owners, employees and consumers, one of the community leaders and the local BPJPH.

Activities in qualitative data analysis are carried out interactively and take place continuously until completion, so that the data is saturated. Activities carried out in this data analysis are data classification, data presentation, and data verification. The data analyzed were previously collected (*data collection*), the data collected were data derived from observations related to the *halal value chain* in the slaughterhouse chicken business, interviews, and documentation.

The data analysis stage begins with the data reduction/collection process, then the reduced data is presented systematically in narrative form. The last step is data verification or drawing conclusions.

The data analysis process in this study is as follows<sup>15</sup>:

---

<sup>11</sup> Heni Pratiwi et al., "Halal Slaughterhouse To Achieve Halal Value Chain Of The Restaurant And Meat-Processed Food Industry," ... *International Seminar of ...* 4 (2023): 1201–6, <https://jurnal.umsu.ac.id/index.php/insis/article/view/13934>.

<sup>12</sup> Popi Rahmaniati and Dini Nur Hakiki, "Perancangan Sistem Jaminan Halal (SJH) Di Rumah Potong Ayam TPA Akbar Bandar Lampung," *IJMA: International Journal Mathla'ul Anwar of Halal Issues* 1, no. 2 (2021): 89–98.

<sup>13</sup> Siregar and Zahradika, "Halal Traceability System (Hts) Untuk Integrasi Halal Meat Supply Chain (Hmsc) Terhadap Proses Industri Daging Ayam Pada Rumah Potong Hewan."

<sup>14</sup> Amrun Hamidi Nst and Dini Wahyuni, "Analisis Risiko Halal Supply Chain Dengan Adopsi Model SCOR (Supply Chain Operations Reference)," *Talenta Conference Series: Energy and Engineering (EE)* 2, no. 4 (2019), <https://doi.org/10.32734/ee.v2i4.676>.

<sup>15</sup> Sugiono, *Metode Penelitian Kuantitatif, Kualitatif Dan R&D* (Bandung: Alfabeta, 2016).

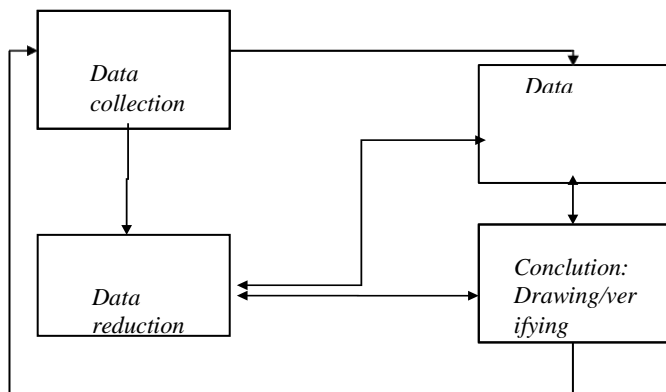

**Figure 3.** Data Analysis Stage of Miles and Huberman Model

After the data is analyzed, the next step is to test data validation using data triangulation techniques. That is checking data from various sources in various ways and various times. Triangulation of sources and techniques is done by checking data from several sources, namely the owner, employees, and consumers of RPA with several techniques, namely interviews, observation, and documentation. Time triangulation is done by conducting interviews and observations at several different times and conditions.

### C. RESULTS AND DISCUSSION

#### 1. Analysis of *Halal Value Chain Practices in Slaughtering and Processing of Beef Chicken at AFJ JAYA Sembayat*

There are several definitions of halal food and drink, including halal in substance, halal in the process and halal in the way it is obtained.<sup>16</sup> In order to find out how to slaughter halal chicken, it is necessary to analyze the *halal value chain* to see the steps of cutting chicken. In Arabic, halal comes from the word *حلال* meaning permitted, it can also be read *hallal* or *halal*, which refers to what is permitted or halal in Islamic law.<sup>17</sup>

While the *value chain* is a series of activities carried out at each stage carried out, starting from the production stage until it becomes a

finished product that will be distributed to consumers' hands ready for consumption, in order to increase the value or utilization of goods or services that are of value to consumers. Animals that are to be slaughtered have met the requirements such as the animal must be alive and the condition must be healthy. Slaughter is carried out using a very sharp knife that has previously been sharpened by workers every time they want to carry out slaughter.

This is in accordance with the provisions of MUI fatwa Number 12 of 2009 concerning halal slaughter certification standards regarding slaughter tools. When slaughtering the position of the worker and the chicken to be slaughtered facing the Qibla and slaughtering is carried out with the intention of slaughtering and chanting the name of Allah with one quick incision that can immediately cut the respiratory tract, feeding tract, and two blood vessels. In accordance with the provisions of MUI fatwa No. 12 of 2009 concerning Halal Slaughter Certification Standards<sup>18</sup>.

From the results of interviews and observations, it can be concluded that the practice of slaughtering chickens in the AFJ JAYA Sembayat chicken slaughterhouse has paid attention to the halal status and is in accordance with the provisions of the MUI fatwa No. 12 of 2009 concerning halal slaughter certification standards. AFJ JAYA Sembayat chicken slaughterhouse strives to maintain quality and halalness in producing chicken meat in accordance with Islamic principles, starting from the slaughterer, the tools used, to the process of slaughtering chickens. If there are chickens that have defects, they will not be sold and dead chickens will be immediately discarded because they cannot be consumed and can be said to be haram. However, there are chicken processing practices that are not in accordance with the provisions of MUI fatwa No. 12 of 2009 concerning halal slaughter certification standards, because in the practice of chicken processing, the place for slaughtering and processing chicken is not separated so that it is done in the same place.

<sup>16</sup> Atiqah Hamid, *Buku Pintar Halal Haram Sehari-Hari* (Yogyakarta: Diva Press, 2012).

<sup>17</sup> Amir and Subroto, "The Creating of Halal Value

Chains: A Theoretical Approach."

<sup>18</sup> Ma'ruf Amin, *Himpunan Fatwa Majelis Ulama Indonesia Sejak 1975* (Jakarta: Erlangga, 2011).

The slaughter and processing process at AFJ JAYA Sembayat chicken slaughterhouse is described as follows:

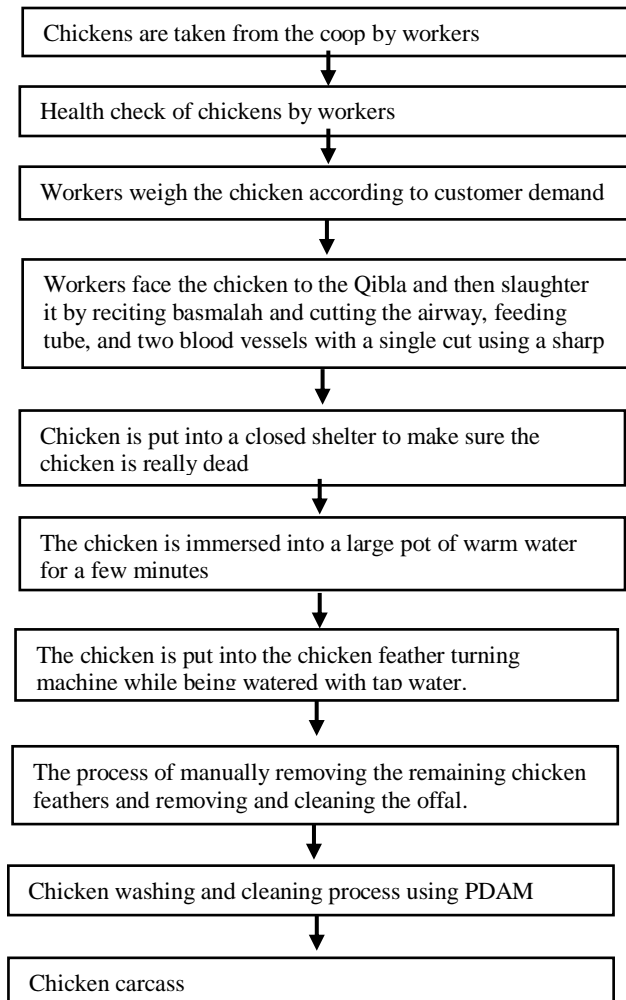

Figure 4

The process of slaughtering and processing chickens at AFJ JAYA Sembayat Chicken Slaughterhouse

## 2. Analysis of Halal Value Chain of Slaughtered Chicken Business at AFJ JAYA Sembayat in Islamic Economic Perspective

*Halal value chain* is created from a series of economic activities that include interconnected production, distribution and consumption processes.<sup>19</sup> *Halal value chain* of slaughtered chicken business at AFJ JAYA Sembayat Chicken Slaughterhouse is divided into five *primary activities* and four *support activities*. Based on the results of *halal value chain*

activities at AFJ JAYA Sembayat Chicken Slaughterhouse can be described as follows:

### Primary Activities

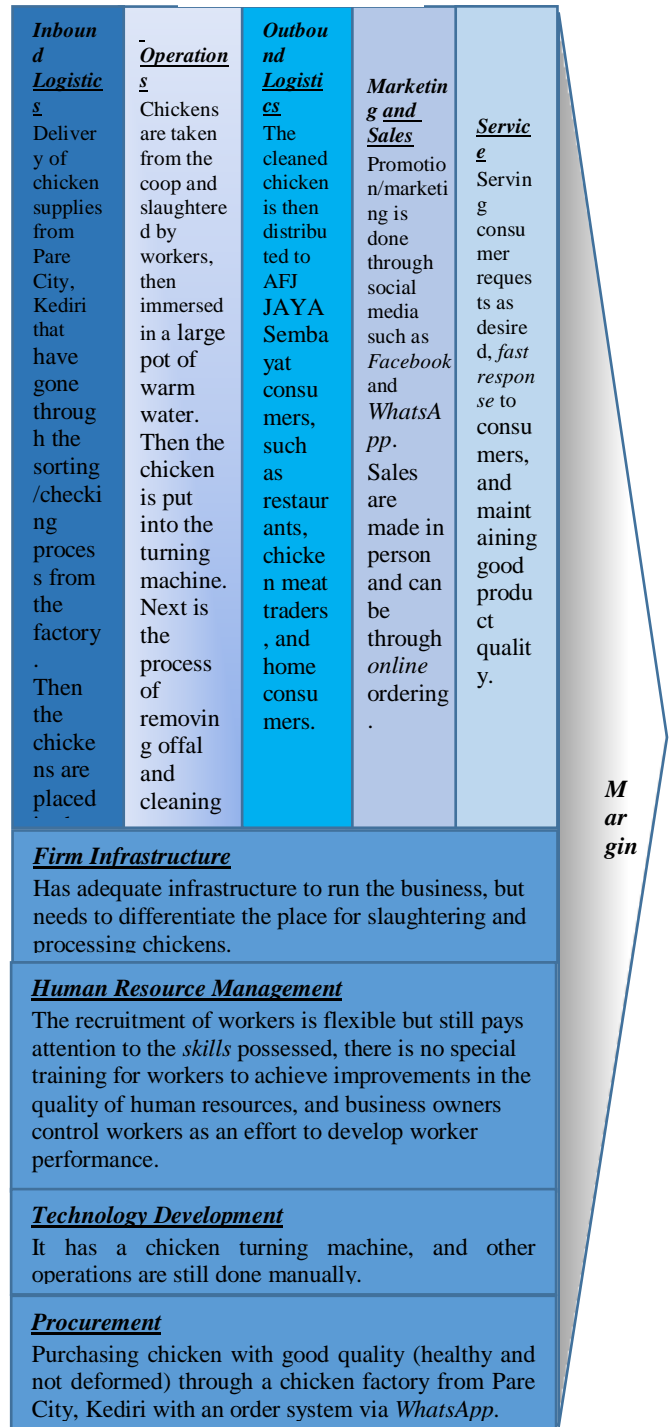

### Support Activities

Figure 5. Value Chain at AFJ JAYA Sembayat Chicken Slaughterhouse

<sup>19</sup> Amir and Subroto, "The Creating of Halal Value

Chains: A Theoretical Approach."

Furthermore, *halal value chain* activities in the economy at AFJ JAYA Sembayat Chicken Slaughterhouse are as follows:

- a. *Halal value chain of production activities*  
*Halal value chain of production activities* is all activities regarding space and time that produce goods or services that have halal value and all activities that add value both in terms of materials and moral usefulness. Production activities at AFJ JAYA Sembayat Chicken Slaughterhouse include slaughtering, which is turning live chickens into chicken carcasses that are ready for consumption by consumers.  
Chickens that are about to be slaughtered will go through a selection process to separate between healthy and defective chickens, after which the weight of the chicken is weighed. The chickens that are slaughtered are alive and in good health.  
Before slaughtering chickens, workers first sharpen the knives that will be used for slaughtering to facilitate the slaughtering process so as not to torture the animals so as to fulfill the requirements of animal slaughtering tools in Islamic law.  
Chickens that are about to be slaughtered will be taken from the cage and put into a large closed basket which will then be weighed. The chickens are then slaughtered by Muslim workers who have expertise in slaughtering animals and understand the slaughter process in accordance with Islamic teachings, such as slaughtering by facing the animal to the Qibla with the intention of slaughtering and reciting "*Bismillah*" and fulfilling the conditions of slaughter in Islam by cutting the respiratory tract, feeding tract, and two right and left veins.  
However, in the practice of chicken processing, there are things that are not in accordance with the provisions in MUI Fatwa No. 12 of 2009 concerning Halal Slaughter Certification Standards. This is because in the practice of chicken processing, the place for slaughtering and processing chicken is carried out in the

same place so that there is no separation between clean and dirty spaces.

- b. *Halal value chain of distribution activities*  
The distribution of slaughtered chicken at AFJ JAYA Sembayat Chicken Slaughterhouse is carried out directly to consumers who make purchases directly at the location and through delivery by workers for customers who place orders via social media. In distributing chicken to consumers, only large red plastic bags are used.  
Related to the principle of distribution in the Islamic economic system, which includes the prohibition of usury and gharar and the existence of justice in distribution.<sup>20</sup>AFJ JAYA Sembayat Chicken Slaughterhouse has fulfilled this concept. It can be seen from the products distributed that do not contain elements of usury and gharar, where it is clear that what is distributed is in the form of chicken carcasses with clear weights and prices listed in the purchase note. So that consumers can find out the weight of chicken carcasses along with the nominal price.
- c. *Halal value chain of consumption activities*  
*Halal value chain of consumption activities* is all activities regarding space and time about spending and using the value of goods or services that have halal value as well as activities that utilize the value or usefulness of goods or services. Chicken is one of the land animals that is halal to eat. However, despite its halal status, the way to obtain it must also be in a halal manner and not violate Islamic law.  
Islam has taught that in consuming food, it must be able to meet the standards of *halalan thayyiban*, avoid impurities (*najis*), be allowed, and be safe for health. Humans are forbidden to eat livestock meat unless it is slaughtered according to Islamic rules. However, Islamic law has excluded two animals from the category of carrion, namely locusts and fish with all kinds of animals that live in water.

---

<sup>20</sup> Ruslan Abdul Ghofur Noor, *Konsep Distribusi Dalam Ekonomi Islam Dan Format Keadilan Ekonomi*

*Di Indonesia* (Yogyakarta: Pustaka Pelajar, 2013).

Based on the description above, it shows that the *halal value chain* in the AFJ JAYA Sembayat Chicken Slaughterhouse business has been fulfilled and implemented effectively. In connection with the results of interviews from several informants, business owners have paid attention to the *halal value chain* in their business in order to maintain the halal status of their products. However, the infrastructure in the form of AFJ JAYA's business premises has not been fulfilled properly because the place is not large enough so that chicken slaughtering and processing activities are still in the same room. Waste disposal also needs to be considered to ensure it does not harm the surrounding environment. In addition, *halal value chain* activities in the economy at AFJ JAYA Sembayat Chicken Slaughterhouse are in accordance with Islamic law, starting from the value chain of production activities, the value chain of distribution activities, to the value chain of consumption activities.

### **3. Consumer's View of Halal Value Chain at AFJ JAYA Sembayat Slaughterhouse Chicken Business**

The AFJ JAYA Sembayat Chicken Slaughterhouse business in fact does not have a halal logo on its packaging and the business itself does not have halal certification as an effort to protect consumers. This is because the business owner thinks that his business does not really need halal certification because the business is not a type of ready-to-eat food business. However, this business has been registered in the Business Identification Number (NIB).

Although it does not yet have halal certification, AFJ JAYA Sembayat has many customers and supplies chicken meat to several restaurants and chicken meat traders, besides that there are also quite a lot of customers from the surrounding community.

In purchasing slaughtered chicken at AFJ JAYA Sembayat Slaughterhouse, consumers claim to have believed that the slaughterhouse is honest and very transparent both regarding

product quality and price.

Based on the results of interviews and observations, it can be concluded that the AFJ JAYA Sembayat Chicken Slaughterhouse above has fulfilled the consumer rights listed in article 4 of Law Number 8 of 1999 concerning Consumer Protection. Consumer views on the *halal value chain* in the AFJ JAYA Sembayat chicken slaughterhouse show that even though the business does not yet have a halal logo on its packaging and has not registered for halal certification, consumers still choose to continue making purchases because they are sure that the chicken meat produced is halal and of high quality. In addition, consumers also get friendly and satisfying service. However, AFJ JAYA Sembayat has not fully fulfilled the right to security and safety of consumers in consuming goods and / or services because this business has not been registered for halal certification and does not have a halal logo on its packaging due to the lack of understanding of business owners regarding the importance of halal certification for the Chicken Slaughterhouse industry.

### **D. CONCLUSION**

From the results of the research and analysis of the discussion described above, the following conclusions can be drawn:

1. The practice of slaughtering chickens at AFJ JAYA Sembayat Chicken Slaughterhouse has paid attention to the halal status and is in accordance with the provisions of MUI Fatwa Number 12 of 2009 concerning Halal Slaughter Certification Standards. AFJ JAYA Sembayat Chicken Slaughterhouse strives to maintain quality and halalness in producing chicken meat in accordance with Islamic principles, starting from the slaughterer, the tools used, to the process of slaughtering chickens. If there are chickens that have defects, they will not be sold and dead chickens will be immediately discarded because they cannot be consumed and can be said to be haram. However, the practice of chicken processing is not in accordance with the provisions of MUI Fatwa Number 12 of 2009 concerning Halal Slaughter Certification Standards, because it is not separated between the place of slaughter and

chicken processing so that it is carried out in the same place.

2. *Halal value chain* in the AFJ JAYA Sembayat Chicken Slaughterhouse business has been fulfilled and implemented effectively. Business owners have paid attention to the *halal value chain* in their business in order to maintain the halal status of their products. However, the infrastructure in the form of AFJ JAYA Sembayat's business premises has not been fulfilled properly because the place is not large enough so that chicken slaughtering and processing activities are still in the same room. Waste disposal also needs to be considered to ensure that it does not harm the surrounding environment. In addition, *halal value chain* activities in the economy

at AFJ JAYA Sembayat Chicken Slaughterhouse are in accordance with Islamic law, starting from the value chain of production activities, the value chain of distribution activities, to the value chain of consumption activities.

3. AFJ JAYA Sembayat business has not registered for halal certification due to the lack of understanding of business owners regarding the importance of halal certification for the Chicken Slaughterhouse industry so that it has not fully fulfilled the right to security and safety of consumers in consuming goods and / or services. However, consumers still choose to continue making purchases because they already feel confident that the chicken meat produced is halal and of high quality.

## REFERENCES

- [1] Amin, Ma'ruf. *Himpunan Fatwa Majelis Ulama Indonesia Sejak 1975*. Jakarta: Erlangga, 2011.
- [2] Amir, Abdul Siaidir, and Waspodo Tjipto Subroto. "The Creating of Halal Value Chains: Theoretical Approach." *IOSR Journal of Economics and Finance* 10, no. 1 (2019): 14–22. <https://doi.org/10.9790/5933-1001011422>.
- [4] Amrun Hamidi Nst, and Dini Wahyuni. "Analisis Risiko Halal Supply Chain Dengan Adopsi Model SCOR (Supply Chain Operations Reference)." *Talenta Conference Series: Energy and Engineering (EE)* 2, no. 4 (2019). <https://doi.org/10.32734/ee.v2i4.676>.
- [5] Apriani, Fitri. "Penerapan Sistem Jaminan Halal Pada Rumah Potong Hewan (Rph) Ruminansia Kota Singkawang." *Cross-Border* 5, no. 2 (2022): 1717–23.
- [6] Hamid, Atiqah. *Buku Pintar Halal Haram Sehari-Hari*. Yogyakarta: Diva Press, 2012.
- [7] Muhammad Yusuf Qardhawi. *Halal Dan Haram Dalam Islam*. Surabaya: Bina Ilmu, 2010.
- [8] Noor, Ruslan Abdul Ghofur. *Konsep Distribusi Dalam Ekonomi Islam Dan Format Keadilan Ekonomi Di Indonesia*. Yogyakarta: Pustaka Pelajar, 2013.
- [9] OPOP Jabar. "Halal Value Chain Jadikan Indonesia Sebagai Pusat Ekonomi Dan Keuangan," n.d. <https://opop.jabarprov.go.id/halal-value-chain-jadikan-indonesia-sebagai-pusat-%0Aekonomi-dan-keuangan-syariah/,%0A>.
- [10] Pratiwi, Heni, Qorry Ambiya, Muhammad Nanda Saputra, and Universitas Jambi. "Halal Slaughterhouse To Achieve Halal Value Chain Of The Restaurant And Meat-Processed Food Industry." ... *International Seminar of ...* 4 (2023): 1201–6. <https://jurnal.umsu.ac.id/index.php/insis/article/view/13934>.
- [11] Rahmaniati, Popi, and Dini Nur Hakiki. "Perancangan Sistem Jaminan Halal (SJH) Di Rumah Potong Ayam TPA Akbar Bandar Lampung." *IJMA: International Journal Mathla'ul Anwar of Halal Issues* 1, no. 2 (2021): 89–98.
- [12] Setiawan, Amelia, and Ria Satyarini. "LAPORAN Identifikasi Dan Analisis Value Chain Pada Usaha Kecil Yang Dikelola Mahasiswa Disusun Oleh : Amelia Setiawan , SE ., MAk ., AK ., CISA Ria Satyarini , SE ., MSi Lembaga Penelitian Dan Pengabdian Kepada Masyarakat Universitas Katolik Parahyangan," 2015, 1–22.
- [13] Siregar, Muhammad Lutfi, and Afuan Zahradika. "Halal Traceability System (Hts) Untuk Integrasi Halal Meat Supply Chain (Hmsc) Terhadap Proses Industri Daging Ayam Pada Rumah Potong Hewan." *Agroindustrial Technology Journal* 7, no. 1 (2023): 74–87. <https://doi.org/10.21111/atj.v7i1.9418>.
- [14] Subianto, Pratiwi. "Rantai Nilai Dan Perspektif Kesadaran Masyarakat Muslim Akan Makanan Halal." *Conference on Islamic Management Accounting and Economics* 1 (2018): 141–46.
- [15] Sugiono. *Metode Penelitian Kuantitatif, Kualitatif Dan R&D*. Bandung: Alfabeta, 2016.
- [16] Wisdaningrum, Oktavima. "Analisis Rantai Nilai ( Value Chain ) Dalam Lingkungan Internal Perusahaan." *Jurnal Analisa* 1, no. 1 (2013): 40–48.